

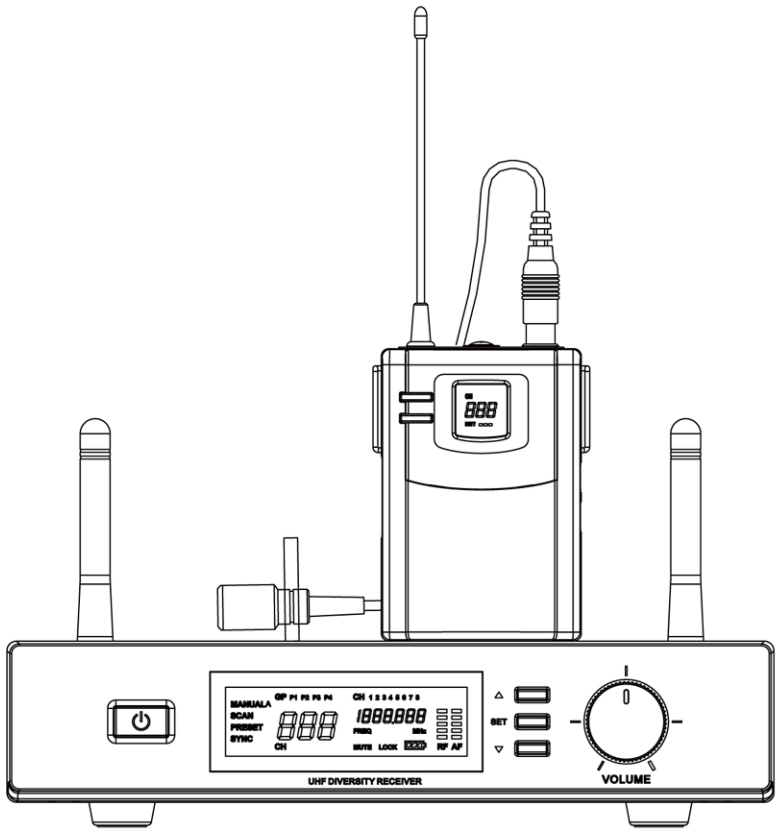

# UHF

## PLL SYNTHESIZED WIRELESS MICROPHONE SYSTEM

# USER MANUAL

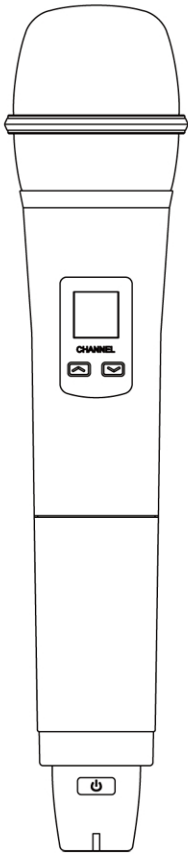

# WIRELESS MICROPHONE SYSTEM

Table of contents	Page
<b>1. Introduction</b> .....	<b>1</b>
<b>2. Safety</b> .....	<b>1</b>
<b>3. Environment</b> .....	<b>1</b>
<b>4. Wireless Note</b> .....	<b>1</b>
<b>5. Product Description</b> .....	<b>2</b>
5.1 Receiver	
5.2 Handheld Transmitter Microphone	
5.3 Bodypack Transmitter	
<b>6. Setting Up</b> .....	<b>6</b>
6.1 Connecting the Receiver	
6.2 Setting up channel on receiver	
6.2.1 Manual Mode	
6.2.2 Auto-Scan Mode	
6.2.3 Preset Mode	
6.3 Setting up the handheld microphone / Bodypack transmitter	
6.4 Low Battery	
6.5 Adjusting Gain	
<b>7. Basic Connections</b> .....	<b>12</b>
<b>8. Trouble Shooting</b> .....	<b>14</b>
<b>9. System Feature</b> .....	<b>14</b>
<b>10. System Specification</b> .....	<b>15</b>

## FCC Statement

This device complies with part 15 of the FCC rules. Operation is subject to the following two conditions: (1) This device may not cause harmful interference and (2) This device must accept any interference received, including interference that may cause undesired operation

Notice : The changes or modifications not expressly approved by the party responsible for compliance could void the user's authority to operate the equipment.

**IMPORTANT NOTE:** To comply with the FCC RF exposure compliance requirements, no change to the antenna or the device is permitted. Any change to the antenna or the device could result in the device exceeding the RF exposure requirements and void user's authority to operate the device.

## 1. Introduction

Thank you for purchasing our product. This wireless microphone system operates in UHF band frequency with synthesizer controlled. The system with 700 selectable frequencies via Phase Locked Loop (PLL) circuitry makes it easy to choose non-interfered channels. (The number of frequency channels depends on local regulations.) Please read this instruction manual carefully before operating the system. This manual covers the function and operation of the wireless microphone system.

## 2. Safety

- Do not spill liquid on the appliance and do not drop it on a hard concrete floor.
- Do not place the appliance near heat sources such as radiators, amplifier, or etc. Do not expose it to direct sunlight, extremely dust, excessive moisture, or vibration.
- Take out the battery from transmitter, if the appliance has been not used for a longer period. This will avoid the damage resulting from a defective leaking battery

## 3. Environment

- Do not throw used batteries into a fire or garbage bin with domestic rubbish. Be sure to dispose of used batteries in accordance with local waste disposal rules.
- When disposing the equipment, remove the batteries, separate the case, circuit boards, and cables, and dispose of all components in accordance with local waste disposal rules.

## 4. Wireless Note

- Before setting up, make sure that the transmitter and receiver are tuned to the same frequency. Do not use two or above transmitters operating in the same frequency.
- Use good quality batteries to avoid the damage resulting from a defective leaking battery.
- Turn the volume control on the receiver to adjust receiver output level to match input level requirements of an audio mixer or amplifier.
- Use the gain control to adjust the sensitivity of the transmitter's audio to the level of the connected lapel microphone or instrument.
- To avoid interference, do not put the receiver too near metal object and avoid obstructions between transmitter and receiver.
- While checking sound, move the transmitter around the area where you use the system to look for dead spots. If you find any dead spot, change the receiver position. If it does not work, avoid such places.
- Avoid the interference from TV, radio, other wireless appliances and etc.

## 5. Product Description

### 5.1 Receiver

The receivers are used with our 700 selectable channels transmitters. (The number of frequency channels depends on local regulations.) The receiver operates in UHF band frequency with PLL synthesized control. Powered by 12V DC.

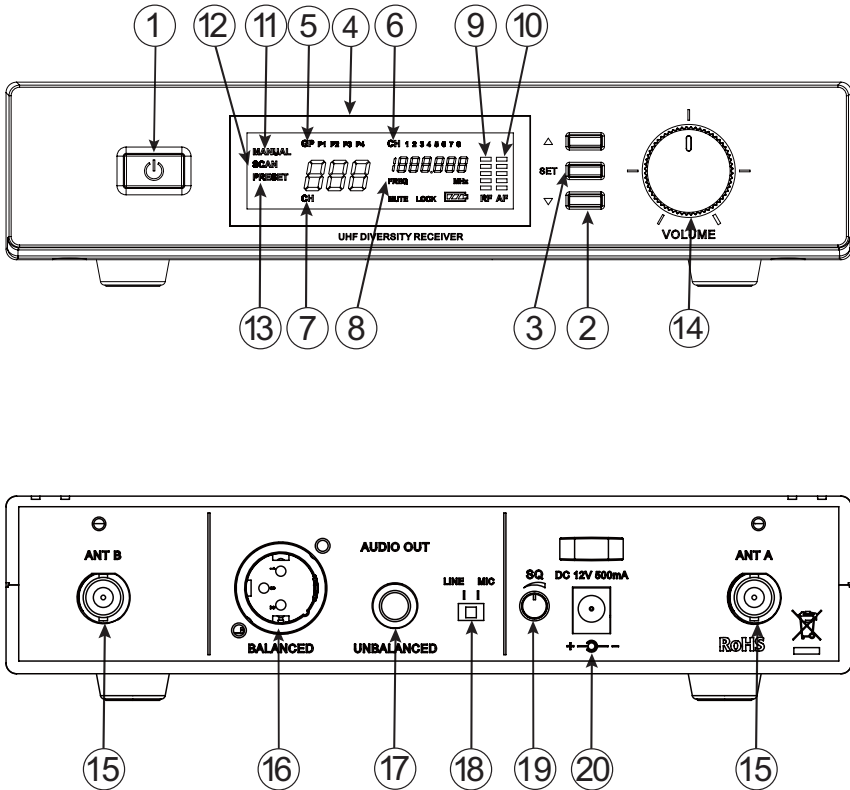

1. **Power:** Press for 4 seconds to power the receiver on or off.
2. **Button  $\triangle \nabla$ :** Used to select your desired mode, and search channel forward.
3. **Set Button:** Press for 2 seconds, until "MUTE" is displayed, release the button, LCD display flashing, press button  $\triangle \nabla$  to change the channel. Stop pressing button and let LCD display flashing five times and then lock the setting.
4. **LCD Display:** Showing the channel number, frequency level, RF & AF signal strength, and set-up mode.
5. **GP:** Indicating the preset group number, ex. P1 or P2...
6. **CH:** Indicating the preset channel number, ex CH1 or CH2...
7. **CH:** Indicating the channel number, ex 001 or 128...
8. **FREQ:** Indicating the frequency.
9. **RF Level Indicators:** 5-segment meter glows to indicate RF signal strength. The more segment glow, the stronger the received signal. If none of these segments glow, no signal is being received.
10. **AF Level Indicators:** 5-segment meter glows to indicate audio signal strength. The more segment glow, the stronger the received signal. If none of these segments glow, no signal is being input.
11. **MANUAL:** Use this mode to select an interference-free channel by manual.
12. **SCAN:** Use this mode to select an interference-free channel by auto-scan function.
13. **PRESET:** Use this mode to select an interference-free channel from preset-groups. There are 4 preset groups. In each group there are sited 8 preset channels which are suitable for 8 transmitters using simultaneously. .
14. **Volume Control:** Use this rotary control to adjust the receiver output level to match the input sensitivity of an audio mixer or an amplifier.
15. **Detachable Antenna Socket:** This provides connection to the supplied antennas or to coaxial cable used with an antenna divider, antenna boosters or remote antennas.
16. **Balanced Output:** 3-pin XLR connector provides balanced low-impedance output
17. **Unbalanced Output:** Unbalanced 6.3mm mono jack audio output for connecting to, e.g., a guitar amplifier.
18. **Mic/Line Switch:** Use this to adjust output (XLR balanced connector and 6.3  $\phi$  unbalanced phone jack) for microphone (-22dBm) or line-level (0dBm).
19. **Squelch:** Use the squelch to adjust the output level to suppress the noise. The higher squelch control, the lower the sensitivity of the receiver and smaller the service area of the system. Set the squelch to minimum before turning the receiver on.
20. **DC IN:** DC Input connector for the supplied AC adapter.

## 5.2 Handheld Microphone

The handheld microphone operates in UHF band frequency with PLL synthesized control. UHF 700 preprogrammed selectable frequencies to avoid interference. (The number of frequency channels depends on local regulations.) Uni-directional dynamic or uni-directional electret condenser cartridges feature different characters for various choices. Use 1.5V x 2 AA size dry or rechargeable batteries for cost-saving and environmental protection.

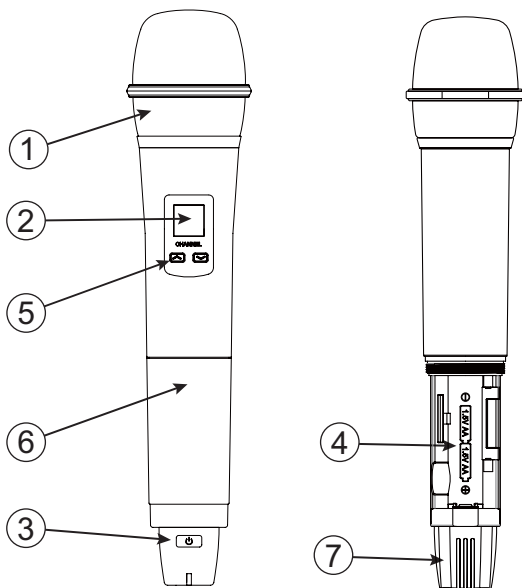

1. **Grille:** Protects the microphone capsule and helps reduce breath sounds and wind noise.
2. **LCD Display:** Displays channel number and battery power level
3. **Power:** Press for 4 seconds to power the transmitter on or off.
4. **Battery Compartment:** Insert two AA dry or rechargeable batteries into the compartment and make sure that the polarity of batteries is correct.
5. **Channel  $\triangle$  or  $\nabla$  Button:** Press power button for 1 second to let LCD display flashing. Press channel  $\triangle$  or  $\nabla$  button to change channel forward or backward.
6. **Battery Cover:** Unscrew to expose battery compartment and SYNC function button.
7. **Antenna:** Permanently connected, helical antenna.

### 5.3 Bodypack Transmitter

The bodypack transmitter operates in UHF band frequency with PLL synthesized control. UHF 700 preprogrammed selectable frequencies to avoid interference. Various uni-directional electret condenser cartridge options. Use 1.5V x 2 AA size dry or rechargeable batteries for low operating cost.

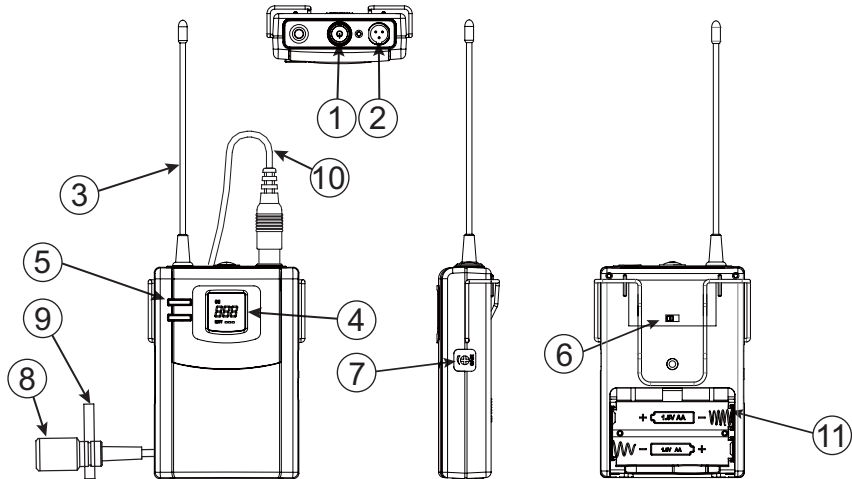

- Power:** Press for 4 seconds to power the transmitter on or off.
- Mini XLR Connector:** The included electret lapel microphone is inserted into the connector on transmitter.
- Antenna:** Permanently connected, helical antenna.
- LCD Display:** Displays channel number and battery power level.
- Channel  $\triangle$  or  $\nabla$  Button:** Press power button for 1 second to let LCD display flashing. Press channel  $\triangle$  or  $\nabla$  button to change channel forward or backward.
- Mic/Line Selector:** The switch sets the audio input either to microphone level or line level.
- Gain:** The rotary control adjusts the input audio level of the transmitter. The gain adjustment range is 10dB.
- Mic Unit:** The uni-directional electret condenser unit features the wide frequency response for warm, rich bass and clear sound.
- Tie Clip:** To clip on the tie or lapel for free-movement.
- Cable:** With mini XLR connector cable to connect the transmitter.
- Battery Compartment:** Insert two AA dry or rechargeable batteries into the compartment and make sure that the polarity of batteries is correct.

## 6. Setting Up

### 6.1 Connecting the Receiver

**NOTICE:** Prior to setting up, please check that the transmitter and receiver are tuned to the same frequency. Two or more transmitters operating in the same frequency can not be used at the same time and area. So for each extra transmitter, please select a different frequency which can be used simultaneously at local area.

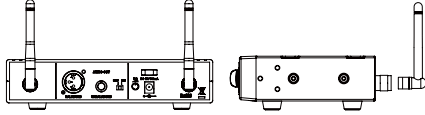
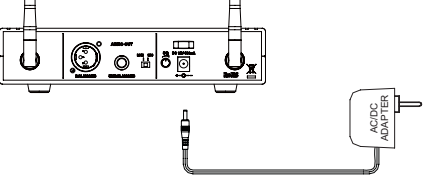
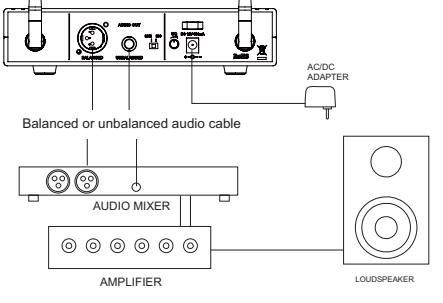
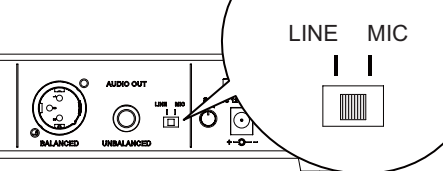
	<ul style="list-style-type: none"> <li>• Plug the antennas into the socket on the receiver and point them upward.</li> </ul>
	<ul style="list-style-type: none"> <li>• Plug the DC 12V 500mA power supply into the power connector on the back of the receiver.</li> </ul>
 <p>Balanced or unbalanced audio cable</p> <p>AC/DC ADAPTER</p> <p>AUDIO MIXER</p> <p>AMPLIFIER</p> <p>LOUDSPEAKER</p>	<ul style="list-style-type: none"> <li>• Connect the receiver output to the audio mixer or amplifier input, using a standard audio cable with 3-pin XLR connectors or 6.3φ phone plugs. Never use the balanced and unbalanced audio outputs at the same time! This may cause signal loss or increased noise.</li> </ul>
 <p>LINE MIC</p> <p>AUDIO OUT</p> <p>BALANCED UNBALANCED</p>	<ul style="list-style-type: none"> <li>• Matching the Mic / Line selector position of receiver with the audio Mixer before connecting with Mixer. For Mic (-20dBm) For Line (0dBm)</li> </ul>



➤ When using a standard audio cable with 3-pin XLR connectors or 6.3 φ phone plugs to plug into the MIC IN on the audio mixer or on the amplifier, please turn the Volume Level Control of the receiver to around 1 o'clock position, the output level for balanced and unbalanced output is about at 77mV.

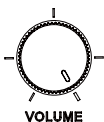

➤ When using a standard audio cable with 3-pin XLR connectors or 6.3 φ phone plugs to plug into the LINE IN on the audio mixer or on the amplifier, please turn the Volume Level Control of the receiver to around MAX. position, the output level for balanced and unbalanced output is about at 770mV. Never use the balanced and unbalanced audio outputs at the same time! This may cause signal loss or increased noise.







**6.2 Setting up channel on receiver**

Notice: Do not put two or more transmitters operating nearby when setting up the frequency channel. Please keep transmitter at least one meter away from receiver.

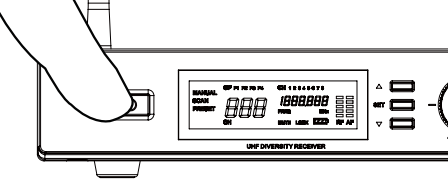

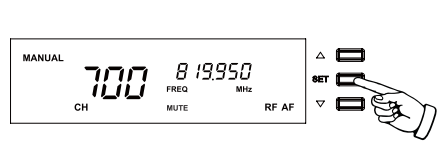
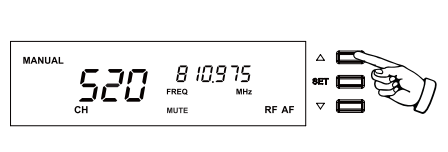
**6.2.1 Manual Mode**

Setting interference-free channel by manual operation.

	<ul style="list-style-type: none"> <li>• Press for 4 seconds to turn on the receiver.</li> </ul>
	<ul style="list-style-type: none"> <li>• Using the <math>\Delta</math> button to select the "MANUAL" mode.</li> </ul>
	<ul style="list-style-type: none"> <li>• Press the "SET" button for 2 seconds until the "MUTE" show up and the LCD display is flashing then release the button.</li> </ul>
	<ul style="list-style-type: none"> <li>• Press button <math>\Delta</math> to change the channel forward.</li> </ul>
	<ul style="list-style-type: none"> <li>• Press the "SET" button to lock the setting or let LCD display flashing five times to lock the setting.</li> </ul>

6.2.2 Auto-Scan Mode

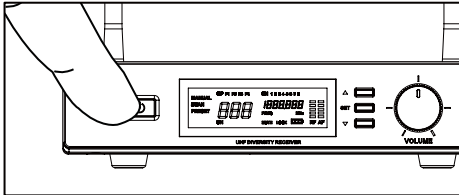
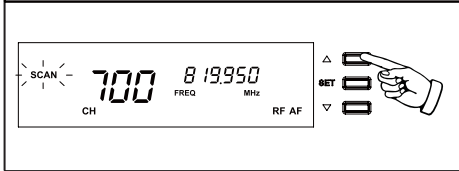
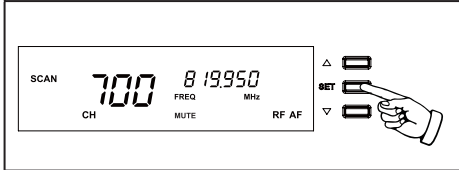
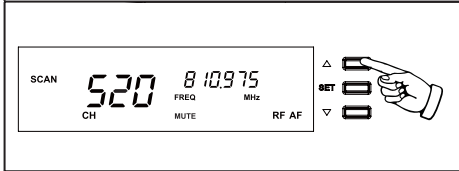





Setting interference-free channel by auto-scan programmed search.

	<ul style="list-style-type: none"> <li>• Press for 4 seconds to turn on the receiver.</li> </ul>
	<ul style="list-style-type: none"> <li>• Using the <math>\Delta</math> button to select the "SCAN" mode.</li> </ul>
	<ul style="list-style-type: none"> <li>• Press the "SET" button for 2 seconds until the "MUTE" show up and the LCD display is flashing then release the button.</li> </ul>
	<ul style="list-style-type: none"> <li>• Press button <math>\Delta</math> to scan in forward direction, and it will stop at the free-interference channel automatically.</li> </ul>
	<ul style="list-style-type: none"> <li>• Press the "SET" button to lock the setting or let LCD display flashing five times to lock the setting.</li> </ul>

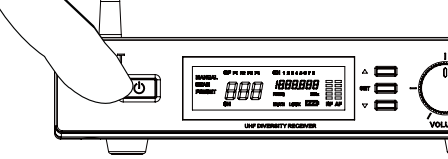
NOTE: If user need to set up a multi-receiver system, please keep your previous receiver-microphone pair power on. Then go on to next scanning procedure.

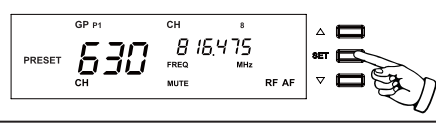
### 6.2.3 Preset Mode

Setting channel by using a default setting channels. There are 4 preset groups. In each group, there are 8 preprogrammed-setting channels. Using a preset group, user can easily set up an 8 receiver-microphone system according the default setting channels of a preset group. Excluding the interference from outside environment, the default setting channels are interference-free to any one of them. User does not need to worry about how to scan 8 channels for a multi-receiver system. User can use a preset group to set up in few steps.

	<ul style="list-style-type: none"> <li>• Press for 4 seconds to turn on the receiver.</li> </ul>
	<ul style="list-style-type: none"> <li>• Using the <math>\Delta</math> button to select the "PRESET" mode.</li> </ul>
	<ul style="list-style-type: none"> <li>• Press the "SET" button for 2 seconds until the "MUTE" show up and the LCD display is flashing then release the button.</li> </ul>
	<ul style="list-style-type: none"> <li>• Press channel button <math>\Delta</math> to change the programmable <b>group forward</b>.</li> </ul>
	<ul style="list-style-type: none"> <li>• Press the "SET" button to lock the group setting or let LCD display flashing five times to lock the group setting.</li> </ul>
	<ul style="list-style-type: none"> <li>• Press channel button <math>\Delta</math> to change the programmable <b>channel forward</b>.</li> </ul>
	<ul style="list-style-type: none"> <li>• Press the set button to lock the channel setting or let LCD display flashing five times to lock the channel setting.</li> </ul>

NOTE: When there is any outside interference on the current preset group, please switch to use next preset group. If 4 preset groups are all under interference, please use auto-scan mode or manual mode to set up system.

**6.3 Setting up the handheld microphone / Bodypack transmitter**

	<ul style="list-style-type: none"> <li>• Open the battery cover and insert batteries into the battery compartment conforming to the polarity (+)(-) marks. The transmitter can not work with incorrectly inserted batteries.</li> </ul>
	<ul style="list-style-type: none"> <li>• Unscrew the handheld Mic and press to open the battery cover to insert the battery into the battery compartment and confirm the marks of the polarity (+) (-). The transmitter works with correctly inserted batteries.</li> </ul>
	<ul style="list-style-type: none"> <li>• Press the button "SET" of the receiver to auto-scan the channel and let LED display flashing to lock the channel automatically.</li> <li>• Use the adjust pin to set the channel of the transmitters as same as the receiver.</li> </ul>
	<ul style="list-style-type: none"> <li>• Plug the mini XLR connector of the microphone cable into the audio input connector on the bodypack transmitter.</li> </ul>
	<ul style="list-style-type: none"> <li>• Press for 4 seconds to turn the Handheld/ Bodypack transmitter on.</li> </ul>

Note : When you don't use this device for a long term period, please switch the power switch to "off" mode to save more electric power.

#### 6.4 Low Battery

When the LCD display shows the low battery power level, it indicates that the battery will run out of power soon and should be changed.

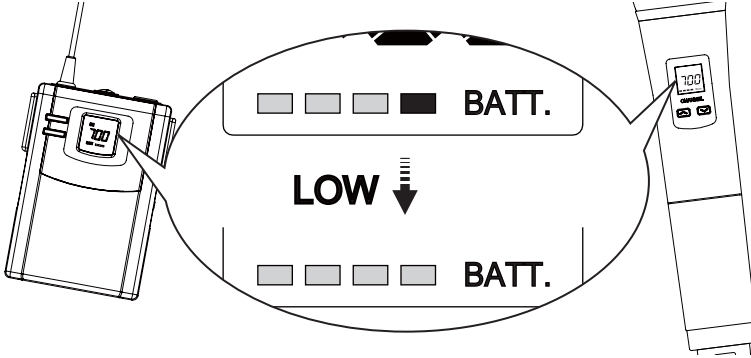

#### 6.5 Adjusting Gain

Use MIC/LINE switch to adjust the input level. Switching the selector to the Mic position when connect with microphone for the normal audio input level. Switching the selector to the Line position when connect with instrument for the high audio input level.

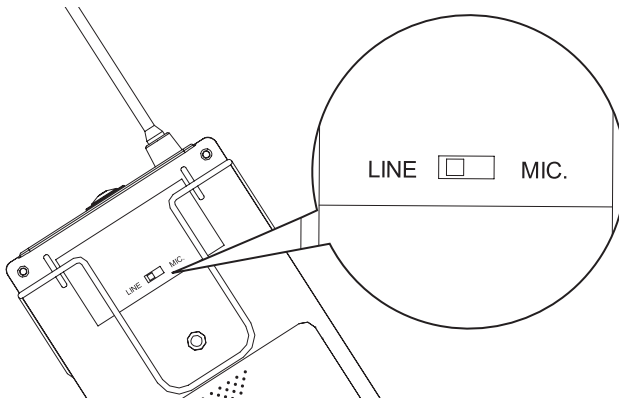

## 7. Basic Connections

To combine two receivers in a 19" standard rack by using 2 short L type plastics racks (L4) and 2 metal connecting plates (C1). (Each system includes a L4 and a C1.)

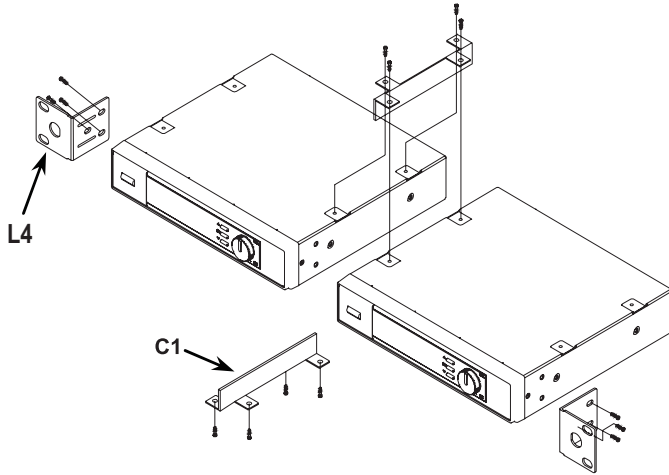

To mount a receiver in a 19" standard rack by using 2 L type long metal racks (L3). (L3 is an optional product, so please purchase extra in local shops.)

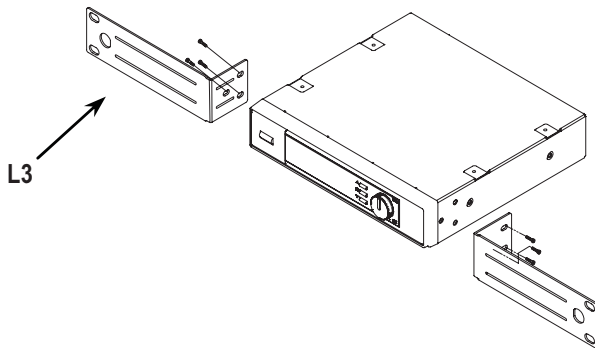

The detachable antenna is highly recommended for long-distance purpose, such as in stadium or in auditorium.

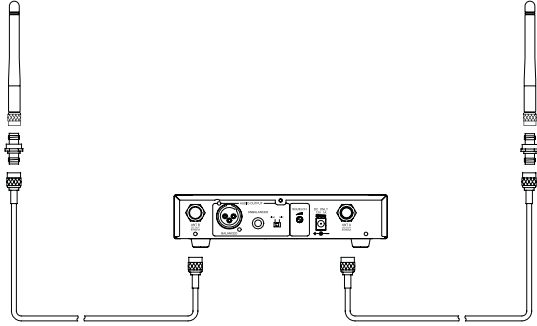

The antenna booster is ideal design for long distance receiving application, ex. if the extended distance exceed 30M.

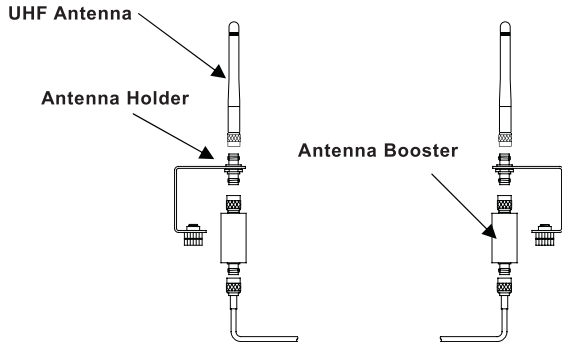

Antenna holder makes it easy to fix wherever for connection antenna and booster. It can be assembled on the mic stand or on the wall.

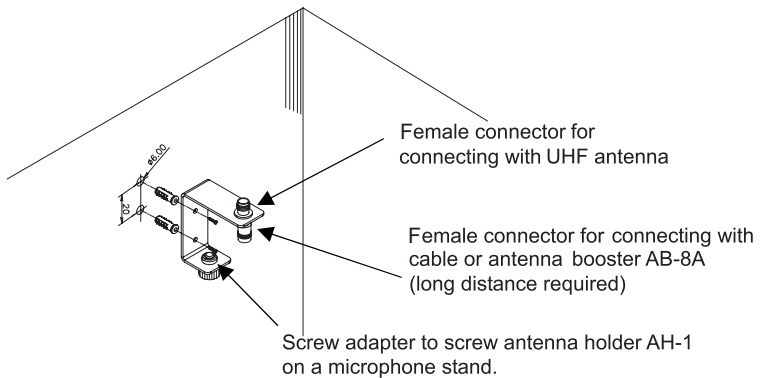

## 8. Trouble-shooting

Problem	Solution
No sound	<ul style="list-style-type: none"> <li>➤ Check the power supply of the microphone and receiver.</li> <li>➤ Check that the transmitter and receiver are tuned to the same frequency.</li> <li>➤ Check whether the hi-fi appliance is switched on and the receiver output is connected to audio mixer or amplifier input.</li> <li>➤ Check whether transmitter is too far away from receiver or SQUELCH control set too high.</li> <li>➤ Check whether receiver is located too near metal object or there are obstructions between transmitter and receiver.</li> </ul>
Sound interference	<ul style="list-style-type: none"> <li>➤ Check the antenna location.</li> <li>➤ When using 2 or above microphone sets simultaneously, make sure that the chosen frequencies are not interfered.</li> <li>➤ Check whether the interference comes from other wireless microphones, TV, radio and etc.</li> </ul>
Distortion	<ul style="list-style-type: none"> <li>➤ Check the receiver volume level is set too high or too low.</li> <li>➤ Check whether the interference comes from other wireless microphones, TV, radio and etc.</li> </ul>

## 9. System Feature

- The flexibility and the professional performance are specifically designed for stages, places of worship, and professional sound installations.
- The UHF wireless microphone system with 700 selectable frequencies via Phase Locked Loop (PLL) circuitry makes it easy to choose non-interfered channels.
- Auto-Scan technology for the operating easiest and fastest channel set-up.
- Super high sensitivity, extremely low noise transmission and reception.
- SMT assembled PCB module ensures the quality and stability.



## 10. System Specification

### Receiver

- Carrier Frequency Range : UHF 520 - 928MHz
- Case : Half 19" EIA-Rack Case
- Oscillator : PLL Synthesized
- Modulation : FM
- Frequency Stability :  $\pm 0.005\%$
- S/N ratio :  $> 94\text{dB}$ , at 20KHz deviation and 60dB $\mu\text{V}$  antenna input
- Image and Spurious Rejection : 80 dB minimum
- Receiving Sensitivity : At 10  $\mu\text{V}$  over 80dB S/N ratio
- Selectivity :  $> 50\text{dB}$
- AF Response : 80Hz to 16KHz
- T.H.D. :  $< 1\%$  (at 1KHz)
- IF Frequency : 1st: 243.95MHz 2nd:10.7MHz
- Dynamic Range :  $> 100\text{dB}$
- Tone Signal : 32.768KHz
- Audio Output : Balanced & Unbalanced
- Power Supply : DC 12V
- Current Consumption : 260mA (MAX)
- Dimension (mm)WxHxD : 200 x 42 x 123

### Handheld/Bodypack Transmitter

- Frequency Range : UHF 520 ~ 928MHz
- Channel Select : ▲▼Tag Switch
- RF Power Output : 10mW (max.)
- Oscillator : PLL Synthesized
- Frequency Stability :  $\pm 0.005\%$
- Deviation :  $\pm 20\text{KHz}$  with limiting compressor
- Spurious Emission :  $> 60\text{dB}$  below carrier frequency
- T.H.D. :  $< 1\%$  (at 1KHz)
- Battery : 1. DC 2.4V (1.2V x 2 AA size rechargeable batteries)  
2. DC 3V (1.5V x 2 AA size batteries)
- Tone Key : 32.768KHz
- Mic Unit : Handheld : Uni-directional dynamic unit (U-283)  
Uni-directional electret condenser unit (ECM-1441)  
Bodypack :Lavalier Mic / Headset Mic
- Display : LCD
- Current Consumption : 120mA  $\pm$  10mA (MAX)
- Dimension (mm)WxHxD : Handheld : 248 x 53 $\Phi$   
Bodypack :65 x 100 x 27

\* The specification subject to change without notice.

<b>WIRELESS</b>	NOTE
-----------------	------

NOTE	<b>WIRELESS</b>
------	-----------------

**ANCHOR AUDIO CUSTOMER SERVICE**  
**800.262.4671**

**FOR ADDITIONAL INFORMATION**  
**visit [www.anchoraudio.com](http://www.anchoraudio.com)**